

Molteni & C

45°/VETRINA— RON GILAD 2013

1—
2



Un mobile vetrato pensato per esporre e custodire oggetti e libri di pregio. Rotazione geometrica dei piani che portano ad angoli smussati a 45° risolti grazie all'impiego di un giunto metallico su cui vengono agganciati profili in alluminio, impiallacciati con essenze pregiate. L'apertura è totalmente invisibile eccetto per una piccola chiave posta sul profilo laterale. Il risultato è un solido trasparente che invita a guardare ciò che in esso viene custodito.

CARATTERISTICHE

Vetrina realizzata con profili d'alluminio rivestito in essenza disponibile nella versione a giorno o con anta. L'anta è sempre dotata di serratura ed è sempre ad apertura DX.

**SCHEDA
TECNICA**

REGISTERED
DESIGN

XII.2014

molteni.it

Dimensioni espresse in millimetri. L'azienda si riserva il diritto di apportare modifiche ai modelli senza preavviso. Le informazioni qui riportate sono basate sugli ultimi dati pubblicati a listino.

FINITURE

Finiture essenze profili e ripiani interni

noce canaletto - rovere nero

Finiture ripiani interni vetro

vetro trasparente o fumé

INFORMAZIONI TECNICHE

BASAMENTO E RIPIANO LEGNO

Pannello multistrato di faggio rivestito con tranciato di legno Noce Canaletto (Juglans nigra) o Rovere (Quercus).

STRUTTURA PERIMETRALE E PROFILI ANTA

Profilo estruso in alluminio rivestito con tranciato di legno Noce Canaletto o Rovere.

CRISTALLI ESTERNI

Cristallo trasparente extrachiario sp. 4 mm. - temperato.

RIPIANO VETRO

Cristallo trasparente extrachiario o fumé sp. 8 mm. - temperato.

Molteni & C

2—

2

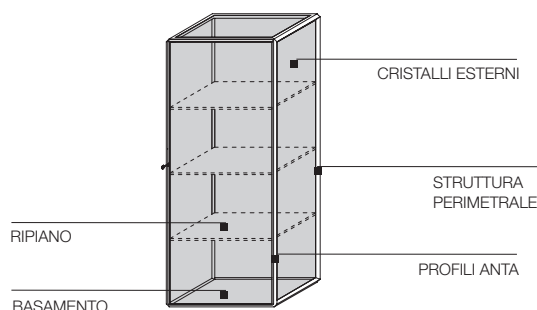

DIMENSIONI

Avvertenze

I 3 ripiani interni sono obbligatori

a giorno

L 595 P 395 H 1440

a giorno con luce led

L 595 P 395 H 1440

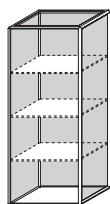

GVG6/14



GVG6/14K

Avvertenze

I 3 ripiani interni sono obbligatori

con anta

L 595 P 410 H 1440

con anta e luce led

L 595 P 410 H 1440

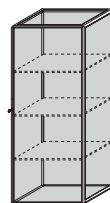

GVA6/14

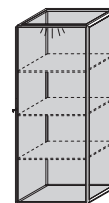

GVA6/14K

ripiano vetro



GVR16

ripiano legno



GVR16

SCHEDA
TECNICA

REGISTERED
DESIGN

XII.2014

FINITURE

	LACCATO OPACO/ LACCATO PORO APERTO	LACCATO LUCIDO	VETRO COLORATO	VETRO ACIDATO COLORATO
BIANCO CALCE	•	•	•	•
AVORIO	•			
PERLA	•	•	•	•
SILICE	•	•	•	•
SABBIA	•	•	•	•
PLATINO	•	•	•	•
DUNA	•	•	•	•
ARGILLA	•	•	•	•
DOLOMITE	•	•	•	•
BORDEAUX	•	•	•	•
MOKA	•	•	•	•
ARANCIO	•	•	•	•
SENAPE	•	•	•	•
CARAMELLO	•	•	•	•
CARTA DA ZUCCHERO	•	•	•	•
ACQUAMARINA	•	•	•	•
ROSSO VENEZIANO	•	•	•	•
PIOMBO	•	•	•	•
ANTRACITE	•	•	•	•
NERO	•	•	•	•
ROSSO LESSLESS	•			
	solo laccato opaco			

FINITURE

ESSENZE

EUCALIPTO



NOCE CANALETTO

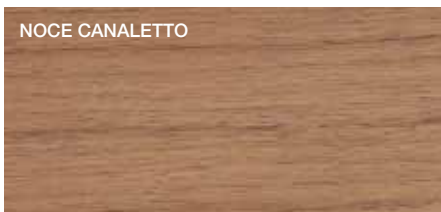

ROVERE GRIGIO

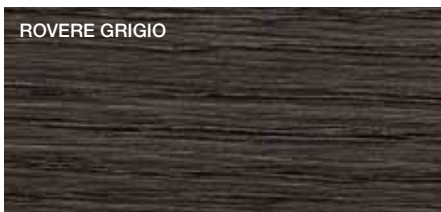

ROVERE NERO

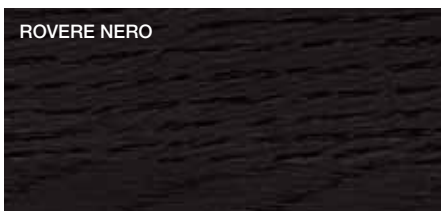

OLMO SCURO



OLMO CHIARO

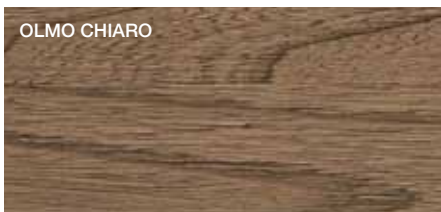

CEDRO



MARMI

MARMO BIANCO CARRARA



MARMO CALACATTA



MARMO ROSSO FRANCIA



MARMO EMPERADOR DARK



MARMO GRIGIO CARNICO

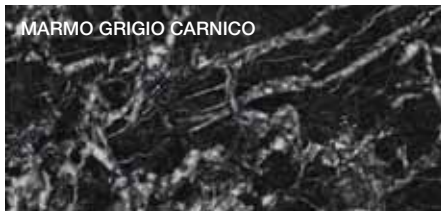

GRANITO NERO ASSOLUTO

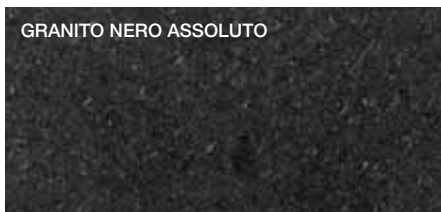

GRES

GRES BIANCO

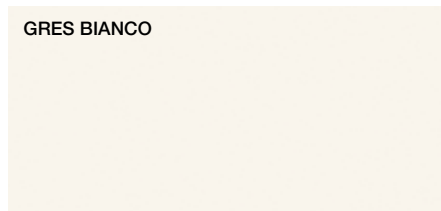

GRES ANTRACITE



PARTI METALLICHE

CROMO NERO

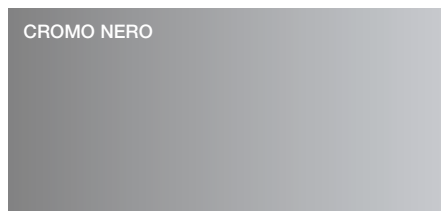

ALLUMINIO LUCIDO

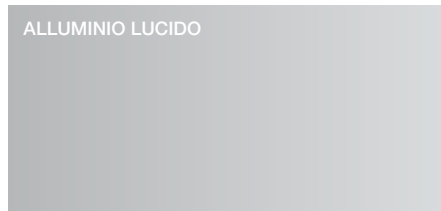

PELTRO



MILLERIGHE
FACCIATA GLISS QUICK

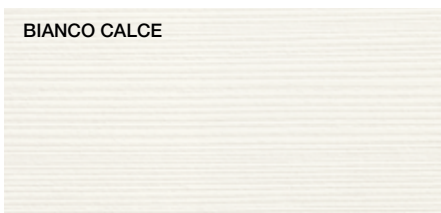

CARTAPAGLIA
FACCIATA GLISS QUICK, GLISS WALK-IN

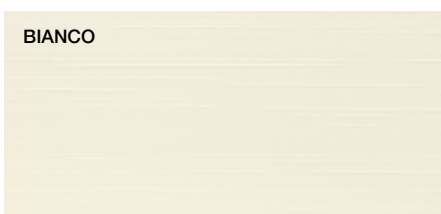

MILLERIGHE
STRUTTURA GLISS QUICK, GLISS 5TH



Millerighe Dark disponibile anche per
Gliss Walk-In dove indicato a listino

DWELL
TELAIO PORTA, PROFILI COPERTURA BINARIO

